

ELGIN®

Subsidiary of Federal Signal Corporation

Road Wizard®



ROAD WIZARD®

BUILT FOR THE MOST DEMANDING JOBS, DESIGNED TO BE THE LEAST DEMANDING TO OPERATE.

The Elgin Road Wizard has been redesigned and improved, retaining all of the features that made it popular including a simplified, dual-engine design while incorporating what our engineers have learned from a 100 year history in sweeping. The result is the best of both worlds; increased operator efficiency and productivity, along with the latest technology for superior results.

Mounted on commercial cab-over or conventional chassis, the Road Wizard is prepared for demanding sweeping applications yet defines operator simplicity. Robust features include a sweep system powered by a low emission, Tier 4 final 74 hp Cummins 2.8 L diesel engine, (74 hp @ 2500 RPM), a sweep path of 10 feet (305 cm), and a large 5.4 cubic yard (4.1 cu meters) hopper designed with a double-scissors lifting mechanism for greater stability, rigidity and trouble free operation.



APPLICATION SOLUTIONS

Elgin Sweeper doesn't offer just one sweeping technology — we take an application-based approach to solving our customers' sweeping needs. Our team works with each customer to ensure that you get a machine that fits your specifications, with the right truck, engine configuration, fuel requirements, and options.

POWERFUL SUPPORT

Elgin sweepers are built for clean, backed for life. Throughout the life of the sweeper, we offer training to your team on proper use and maintenance. We have a world-wide network of experienced dealers with factory trained technicians and a local stock of OEM parts and accessories, to ensure total customer peace of mind.

UNMATCHED QUALITY

The Road Wizard was introduced a decade ago and has been continuously improved. Manufactured in an ISO:9001 certified plant, Elgin Sweepers are quality inspected and functionally tested prior to shipment. Paint prior to assembly ensures uniform, durable coverage. Eagles are proudly assembled in the U.S.A.



HIGH PRODUCTIVITY SWEEP SYSTEM

- Sweep system powered by a low emission, 74 hp Cummins diesel engine, (55 kW @ 2500 RPM), one of the most powerful standard auxiliary engines available on a mechanical sweeper.
- Control console, located between the operator stations, provides quick, easy access for increased productivity and safe operation. All sweep function switches have tactile-feel surfaces, so operators can work the panel while keeping their eyes forward, for added safety and efficiency.
- Dual free-floating gutter brooms adjust to variable road surfaces, a sweep path of 10 feet (305 cm) and a powerful free floating direct-drive main broom, ensure reliable and complete pickup of debris.
- Superior dust control is maintained with an in-cab zone-controlled diaphragm water pump and a 360 gallon (1,363 L) water tank for long sweep times between refills.
- 5.4 cubic yard (4.1 cubic meter) hopper features a center mounted double-scissors lifting mechanism for greater stability and trouble-free operation.
- Dumping height is variable up to 11 feet, 2 inches (3,404 mm) and an 11 inch (279 mm) side shift enables a cleaner more efficient unloading of material.



EASY TO OPERATE. EASY TO MAINTAIN. BUILT TO LAST.



MAIN BROOM

A free-floating trailing arm main broom conforms to road contours. Powered by the auxiliary engine, the main broom works at variable speeds that coincide with auxiliary engine RPM. Productivity is enhanced with automatic settings for down pressure, and wear control. Main broom lift, lower and down-pressure functions are controlled from the cab. The main broom arm bearings are sealed and self-aligning for self-adjustment when experiencing an uneven load. The self-adjusting system guards against premature wear.

SIDE BROOMS

46 inch (1,168 mm) trailing arm, free-floating side brooms offer four-way motion and protection against damaging impacts. Hydraulic lift and extension control enhances performance while sweeping within a 10 foot (305 cm) wide path. Steel plate disc construction adds durability. Broom speed is controlled by hydraulic motors operating at variable speeds that coincide with auxiliary engine RPM. Automatic settings control down-pressure, digging-pressure and wear-control. In-cab side broom pressure gauges and down-pressure control are standard. Each broom uses a dedicated section on the gear pump. This feature allows for the maximum transfer of available horsepower independently to each broom, providing superior digging and sweep performance.



SQUEEGEE TYPE CONVEYOR

A steel roller chain drives an 11-flight, squeegee-type conveyor to load debris into the hopper. The chain operates on polyurethane sprockets, which last longer. Conveyor speed is proportional to engine throttle which allows the squeegee loading rate to adjust to sweeping conditions. Conveyor operating height can be raised from the cab up to three inches to avoid larger debris and other obstacles. Conveyor bearings are sealed and self-aligning for longer life.

AUXILIARY ENGINE

A low-emission 74 hp Cummins diesel engine (55 kW @ 2500 RPM) provides variable control over sweeper functions independent of the chassis. It is among the most powerful standard auxiliary engines available on a mechanical sweeper. Maximum fuel capacity is 50 gallons (189 L). The engine includes a two-stage, dry-type air cleaner with safety element, pre-cleaner, and optional in-cab restriction indicator. In-cab gauges and warning lights are displayed for all engine functions including tachometer, hour meter, volt meter, fuel level, coolant temperature, oil pressure, hydraulic oil filter restriction, engine running, and air filter restriction.



HYDRAULIC SYSTEM

The Road Wizard features a 34 gallon (128 L) reservoir with an external level indicator and thermometer, and a 24 GPM (91 LPM) quad section gear pump capacity at 1200 RPM of the auxiliary engine.



SIMPLE, EASY-ACCESS MAINTENANCE

The Road Wizard is designed so that systems are accessible and easy to service. Large access doors allow for 180 degree accessibility to engine maintenance components. The hydraulic system with o-ring face seal fittings is designed for long life and leak-free operation. Heavy-duty waterproof electrical connectors and color-coded wires have stamped identification for quick location during troubleshooting. A stainless steel toolbox provides additional storage.

SUPERIOR MECHANICAL SWEEPER DESIGN

LARGE VARIABLE HEIGHT DEBRIS HOPPER

The Road Wizard features a variable-height, right side dump hopper with a capacity of 5.4 cubic yard (4.1 cu meters) volumetric. All hopper lift and dump controls are hydraulic and easily operated from in-cab console mounted controls. A 50 degree dump angle allows material to easily slide out.

A unitized, twin-cylinder, double scissors lift rated at 11,000 lbs (4,990 kg) unloads material at a minimum of 38 inches (965 mm) and a maximum of 11 feet, 2 inches (3,404 mm). Payload capacity is 10,000 lbs (4,536 kg) per load. An 11 inch (279 mm) side shift allows material to be unloaded into the center of a truck or container for cleaner dumping.



SUPERIOR DUST SUPPRESSION

A 360 gallon removable water tank is made of corrosion resistant polyethylene. A 16 foot, 8 inch long (5.1 m) fill hose and water level indicator lights located on the control console are standard. Water flow for the side and main brooms is controlled in-cab. The self-priming diaphragm pump (run dry type, 40 psi) provides effective dust control. Three spray nozzles are positioned on each side broom and three on the main broom. Dual water pumps are standard.

MEMORY SWEEP®

Elgin's exclusive Memory Sweep feature allows the operator to resume all previous sweeper settings, even broom tilt if so equipped, with one touch control. This feature enhances operator productivity and reduces operator fatigue. Memory Sweep incorporates a multi-screen display that indicates engine hours and water tank level as well as system diagnostics. This screen also displays optional features such as broom tilt angle and broom hours.

**MEMORY
SWEEP**



UNIQUE APPLICATION VERSATILITY

*PATENTED CONVEYOR FLEXIBILITY

The Road Wizard comes standard with a squeegee type conveyor to load debris into the hopper. This sweep system is designed to provide versatile and reliable performance in a wide range of applications including aggregate and granular material pick up of gravel and millings, ideal for road construction contractors as well as general municipal sweeping of trash, leaves, and other organics.

The Road Wizard is also available with a belt conveyor for applications such as highway sweeping and general municipal sweeping where large debris is encountered.

THE ELGIN SQUEEGEE CONVEYOR

- Chain side-plate constructed from hardened steel for long life and smooth operation.
- Three-piece design for easy service without removing complete assembly.
- Thick, multi-ply rubber-edged flights provide efficient movement of debris into the hopper.
- Unique, interlocking, wavy-plate joint design prevents excessive wear and "thumping" over plate seams.
- Abrasion-resistant steel floor for durability.
- Direct-drive hydraulic motor for optimal power transfer to the conveyor system.



THE ELGIN BELT CONVEYOR

- Standard new Chevron Belt.
- Full-width angled cleats move more material quickly to hopper for maximum productivity.
- Direct-drive hydraulic motor for optimal power transfer to the conveyor system.
- Improved hopper fill by throwing debris towards center of hopper.
- Heavy-duty poly/nylon belt construction resists stretching and requires fewer adjustments.
- Ribs between cleats enhance effectiveness of moving fine debris into the hopper.



Elgin conveyors are designed to be interchangeable should a customer have different applications throughout the sweep season.



OPTIONAL ENHANCEMENTS



LIGHTING PACKAGES

The Road Wizard sweeper can be equipped with a variety of optional lighting packages. Lighting packages are designed for flexibility based on customer requirements and can include strobes, beacons and arrow sticks.



LIFELINER® HOPPER SYSTEM

The LifeLiner hopper system is a specially designed hopper liner and finish system that greatly improves the life, durability, and functionality of a sweeper hopper. The LifeLiner hopper system is backed by a lifetime warranty.*



IN-CAB SIDE BROOM TILT AND EXTENDED REACH

Allows operator to sweep effectively in variably-pitched gutters. On-the-go pitch adjustment with a simple variable rocker switch. Extended reach allows the side broom to follow curbs and tight cul-de-sacs.

ADDITIONAL OPTIONS:

- Variable speed conveyor
- PM-10 compliance package
- Mechanical float main broom suspension
- In-cab, side broom speed and reversing control
- Strobe lamp
- Arrowstick
- Automatic lubrication system
- Front spray bar

SPECIFICATIONS:

SWEEP PATH

Main broom only:
60 in (1524 mm)

Main broom and 1 side broom:
90 in (2,286 mm)

Main broom and 2 side brooms:
120 in (3,048 mm)

HOPPER CAPACITY

Volumetric Capacity: 5.4 yd³ (4.1 cu m³)

HOPPER DUMPING

Minimum dump height: 38 in (965 mm)
Maximum dump height: 11 ft 2 in (3,404 mm)

WATER SPRAY SYSTEM

Tank capacity: 360 gal. (1362 L)

AUXILIARY ENGINE

Cummins 74hp EPA compliant engine

CHASSIS

Conventional
Cab-Over

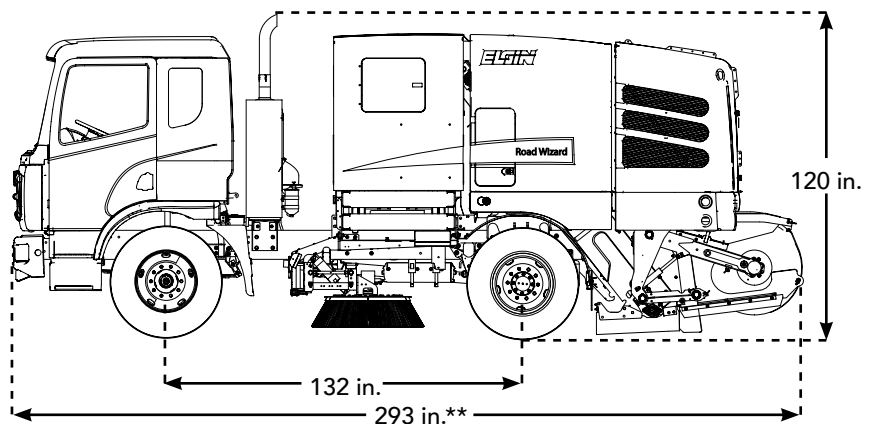

*Consult factory for warranty details **Transport mode

ELGIN SWEEPER IS YOUR PARTNER...

IN THE PLANNING

Instead of one-size-fits-all solutions, we'll work with you to select the sweeping technology that fits your specific needs.



IN THE STREETS

We're here to help you maintain your Elgin and train your operators to ensure the job is done right.



INTO THE FUTURE

Our dealers don't just sell you an Elgin; they're available to answer your questions and provide service for the life of the machine.



WARRANTY

Elgin Sweeper Company backs the Road Wizard sweeper with a one-year limited warranty. The Road Wizard is warranted against defects in material or workmanship for a period of 12 months from the date of delivery to the original purchaser. Optional extended warranty packages are available. Consult your Elgin dealer for complete warranty information.

Your Local Elgin Dealer Is:



elginsweeper.com

1300 W. Bartlett Road • Elgin, IL 60120 U.S.A.

(847) 741-5370 Phone • (847) 742-3035 Fax

Specifications subject to change without notice. Some items shown may be optional. Elgin® Road Wizard®, LifeLiner® and Memory Sweep® are registered trademarks of Elgin Sweeper Company.

©2019 Elgin Sweeper Company. Effective 6/19 P/N 0705323-F